

08/2025

Question Booklet
Alpha Code

A

Question Booklet
Serial Number

Total Number of questions : 100

Time : 1 Hour 30 Minutes

Maximum Marks : 100

INSTRUCTIONS TO CANDIDATES

1. The question paper will be given in the form of a Question Booklet. There will be four versions of question booklets with question booklet Alpha Code viz. A, B, C & D.
2. The Question Booklet Alpha Code will be printed on the top left margin of the facing sheet of the question booklet.
3. The Question Booklet Alpha Code allotted to you will be noted in your seating position in the Examination Hall.
4. If you get a question booklet where the Alpha Code does not match to the allotted Alpha Code in the seating position, please draw the attention of the Invigilator IMMEDIATELY.
5. The Question Booklet Serial Number is printed on the top right margin of the facing sheet. If your question booklet is unnumbered, please get it replaced by new question booklet with same Alpha Code.
6. The question booklet will be sealed at the middle of the right margin. Candidate should not open the question booklet, until the indication is given to start answering.
7. Immediately after the commencement of the examination, the candidate should check that the question booklet supplied to him/her contains all the 100 questions in serial order. The question booklet does not have unprinted or torn or missing pages and if so, he/she should bring it to the notice of the Invigilator and get it replaced by a complete booklet with same Alpha Code. This is most important.
8. A blank sheet of paper is attached to the question booklet. This may be used for rough work.
9. **Please read carefully all the instructions on the reverse of the Answer Sheet before marking your answers.**
10. Each question is provided with four choices (A), (B), (C) and (D) having one correct answer. Choose the correct answer and darken the bubble corresponding to the question number using Blue or Black Ball Point Pen in the OMR Answer Sheet.
11. **Each correct answer carries 1 mark and for each wrong answer 1/3 mark will be deducted. No negative mark for unattended questions.**
12. No candidate will be allowed to leave the examination hall till the end of the session and without handing over his/her Answer Sheet to the Invigilator. Candidates should ensure that the Invigilator has verified all the entries in the Register Number Coding Sheet and that the Invigilator has affixed his/her signature in the space provided.
13. Strict compliance of instructions is essential. Any malpractice or attempt to commit any kind of malpractice in the Examination will result in the disqualification of the candidate.

A

DO NOT WRITE HERE

1. Which of the following is correct about PPE?
- | | |
|------------|-------------------------------------|
| i) PPE 5 | a) Safety belt harness |
| ii) PPE 6 | b) Eyes and face protection |
| iii) PPE 7 | c) Ears protection |
| iv) PPE 8 | d) Protective clothing and coverall |
- (A) i – a, ii – b, iii – d, iv – c
 (B) i – b, ii – c, iii – a, iv – d
 (C) i – c, ii – d, iii – b, iv – a
 (D) i – b, ii – d, iii – c, iv – a
2. Which of the following statement is/are correct related to fire extinguishers?
- (i) The main distinguishing feature of dry powder extinguishers is fork-shaped nozzle.
 (ii) Foam extinguisher is used where electrical equipment is involved.
 (iii) Foam extinguishers are most suitable for flammable liquid fires and running liquid fires.
 (iv) Fire due to electrical equipment can be extinguished by cooling with water.
- | | |
|----------------------|----------------------|
| (A) Only i, ii & iii | (B) Only i & iii |
| (C) Only i & iv | (D) All of the above |
3. Which of the following statement is/are true related to colour code of bins for waste segregation?
- i) Red is used for metal, blue is used for paper and yellow is used for food.
 ii) Yellow is used for paper, red is used for metal and green is used for glass.
 iii) Yellow is used for plastic, red is used for metal and green is used for food.
 iv) Yellow is used for plastic, red is used for metal and green is used for glass
- | | |
|------------------|----------------------|
| (A) Only i & iii | (B) Only iii |
| (C) Only iv | (D) All of the above |
4. In ABC of first aid, 'A' denotes _____
- | | |
|----------------|---------------|
| (A) Attention | (B) Arresting |
| (C) Atmosphere | (D) Airway |

A

5. Which fire extinguisher is filled with Carbon tetrachloride (CTC) and Bromochlorodifluoromethane (BCF)?
- (A) Foam extinguisher
 - (B) Dry powder extinguisher
 - (C) Halon extinguisher
 - (D) Carbon dioxide extinguisher
6. How the fire extinguishers are functioned to stop fire?
- (A) Pull, Aim, Squeeze, Sweep
 - (B) Pull, Aim, Sweep, Squeeze
 - (C) Aim, Squeeze, Pull, Sweep
 - (D) Aim, Pull, Squeeze, Sweep
7. Which of the following is the correct sequence of 5S concept?
- (A) Sort, Shine, Set, Standardize, Sustain
 - (B) Sort, Set, Shine, Sustain, Standardize
 - (C) Sort, Set, Shine, Standardize, Sustain
 - (D) Sort, Set, Sustain, Standardize, Shine
8. Which of the following is correct about fire extinguisher?
- | | |
|----------------|--|
| i) Class 'A' | a) Metals & electrical equipment |
| ii) Class 'B' | b) Wood, paper, cloth and solid material |
| iii) Class 'C' | c) Gas & liquefiable gases |
| iv) Class 'D' | d) Oil based fire (grease, oil etc) |
- (A) i – a, ii – b, iii – d, iv – c
 - (B) i – b, ii – a, iii – c, iv – d
 - (C) i – c, ii – d, iii – b, iv – a
 - (D) i – b, ii – d, iii – c, iv – a
9. What is the shape of warning signs?
- | | |
|----------------|----------------------|
| (A) Square | (B) Circular |
| (C) Triangular | (D) Square of oblong |

10. Which of the following statement is/are true related to first aid?
- i) Place a pillow under the head of an unconscious person.
 - ii) Give an unconscious person any food or drink.
 - iii) Splash water on the face of an unconscious person to revive him.
 - iv) Do not leave the unconscious person alone.
- (A) Only iv (B) Only i & iii
(C) Only iii (D) All of the above
11. One micron is equal to _____
- (A) 0.1 mm (B) 1 mm
(C) 0.001 mm (D) 0.01 mm
12. Which marking media give very clear lines but take more time for drying than the other marking media?
- (A) Whitewash
(B) Prussian blue
(C) Marking blue
(D) Cellulose lacquer
13. Which caliper has one leg with adjustable divider point while the other leg is a bent leg?
- (A) Divider
(B) Inside caliper
(C) Outside caliper
(D) Jenny caliper
14. Which among the following is NOT a part of the divider?
- (A) Cork (B) Peg
(C) Fulcrum (D) Ball
15. Which punch gives wide and not very deep punching mark?
- (A) Prick punch (B) Centre punch
(C) Pin punch (D) Dot punch

A

16. _____ hammers are used for general work in a machine/fitting shop.
- (A) Straight pein hammer
 - (B) Cross pein hammer
 - (C) Ball pein hammer
 - (D) Sledge hammer
17. Which among the following is NOT a use of try square?
- (A) Measuring 90°
 - (B) Set work pieces at right angles
 - (C) Check the squareness
 - (D) Mark lines 90° at the edges of the workpiece
18. The protractor head is used for marking and measuring angles with an accuracy of _____ degree.
- (A) 0.5°
 - (B) 0.05°
 - (C) 2°
 - (D) 1°
19. Surface plates used for machine shop works are available _____ grades.
- (A) Grade 1
 - (B) Grades 1 and 2
 - (C) Grades 1, 2 and 3
 - (D) Grades 1, 2, 3 and 4
20. Which parallel block is used for general machine shop work?
- (A) Grade A
 - (B) Grade B
 - (C) Grade C
 - (D) Grade D
21. Which are the correct statements in the case of screw thread micrometer?
- i) It is a measuring instrument and accuracy of this instrument is 0.001 mm
 - ii) It is a measuring instrument and accuracy of this instrument is 0.01 mm
 - iii) Screw thread micrometer is an instrument used for measuring pitch diameter of screw thread
 - iv) Screw thread micrometer is an instrument used for machining and ensure the profile of screw thread
- (A) i & ii
 - (B) ii & iii
 - (C) i & iv
 - (D) i & iii

22. Name the Vernier height gauge part shown in figure.

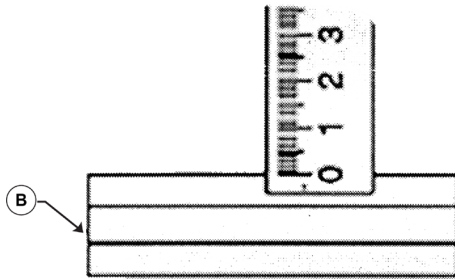

- (A) Head (B) Slider
(C) Base (D) Heel

23. Which are the correct statements in the case of inside micrometer?

- i) The circumference of the bevel edge of the thimble is graduated into 50 divisions.
- ii) The circumference of the bevel edge of the thimble is graduated into 25 divisions.
- iii) In one complete turn of thimble, it moves forward or backward by one thread pitch of 0.5 mm.
- iv) In one complete turn of thimble, it moves forward or backward by one thread pitch of 0.01 mm

- (A) i & ii (B) ii & iii
(C) iii & iv (D) i & iii

24. The accuracy of common type vernier caliper which is used for measuring turning surface is

- (A) 0.02 mm (B) 0.01 mm
(C) 0.002 mm (D) 0.001 mm

25. Which are the statements applicable in the case of vernier bevel protractor?

- i) Bevel Protractor is an instrument which is used for measuring angle to an accuracy of 5 minutes
- ii) Dial of Bevel Protractor is an integrated part of stock
- iii) Bevel Protractor is an instrument which is used for measuring angle to an accuracy of 5 seconds
- iv) Dial of Bevel Protractor is an integrated part of Blade

- (A) i & ii (B) ii & iii
(C) i & iv (D) i & iii

A

26. Name the part of vernier caliper which moves over the beam and can be set in any position by means of a spring-loaded thumb lever.
- (A) Beam
 - (B) Barrel
 - (C) Vernier scale
 - (D) Vernier slide
27. The working principle of an instrument which states that two different scales are constructed on a single known length of a line and the difference between them is taken for fine measurements.
- (A) Depth Gauge
 - (B) Vernier Caliper
 - (C) External Micrometer
 - (D) English Micrometer
28. In the vernier height gauge, finer adjusting slide has to be locked in position, for an approximate height as required. To get an exact markable height, the finer adjustments have to be carried on the slider with the help of
- (A) Jaw clamp
 - (B) Finer adjusting slide
 - (C) Locking Screw
 - (D) Finer adjusting nut
29. The other name of graduated sleeve of micrometer
- (A) Ratchet
 - (B) Barrel
 - (C) Pitch screw
 - (D) Scriber tip
30. The instrument used to true and align machine tools, fixtures, to test and inspect the size & trueness of finished work to an accuracy of 0.01 mm is
- (A) Screw pitch gauge
 - (B) Bore gauge
 - (C) Dial indicator
 - (D) Depth gauge

31. Among them which are the features of flexible hacksaw blades?

- i) The full length of the blade between the pins is hardened
- ii) The teeth of the blade are only hardened
- iii) Flexible blades should be thinner than all hard blades
- iv) Flexible blades are used for sawing harder metals such as tool steel, die steel

(A) i & ii

(B) ii & iii

(C) i & iv

(D) i & iii

32. Among them which are the features of double cut files?

- i) The first row of teeth is known as OVERCUT and the teeth are cut at an angle of 51°
- ii) The first row of teeth is known as UPCUT and the teeth are cut at an angle of 70°
- iii) The first row of teeth is known as OVERCUT and the teeth are cut at an angle of 70°
- iv) A double cut file has two rows of teeth cut diagonal to each other

(A) i & ii

(B) ii & iii

(C) iii & iv

(D) iv & i

33. Name of the file shown in the picture is

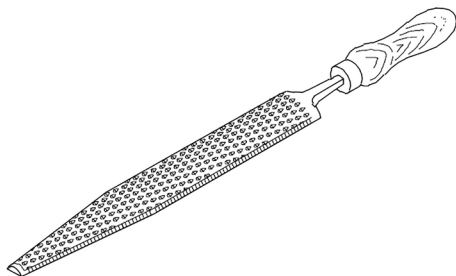

(A) Rasp-cut file

(B) Riffler file

(C) Crossing file

(D) Knife edge file

34. While filing of soft metal, the file teeth to become clogged with metal particle is known as

(A) Piercing of file

(B) Cladding of file

(C) Pinning of file

(D) Binding of file

A

35. Which are the correct statements in the case of hand files?
- i) These files, edges along the width, are parallel throughout the length
 - ii) These type files, one edge is single cut whereas the other is safe edge
 - iii) The edges along the width of these files are parallel up to two-thirds of the length
 - iv) These type files faces are double cut and the edges are single cut
- (A) i & ii (B) ii & iii
(C) i & iv (D) i & iii
36. In ISO Metric Thread, minor diameter of drill hole is
- (A) Major diameter – $1.25 \times$ depth of thread
(B) Major diameter – $1.5 \times$ depth of thread
(C) Major diameter – $1.75 \times$ depth of thread
(D) Major diameter – $2 \times$ depth of thread
37. In the case of crosscut chisel, the length of the chisel varies from 100 to 400 mm and its width of the cutting edge varies from _____
- (A) 16 to 32 mm (B) 4 to 12 mm
(C) 2 to 16 mm (D) 6 to 16 mm
38. While rough reaming operations are carried out by using the reamer, reamers are supposed to remove minimum amount of metal from _____
- (A) 0.1 to 0.15 mm
(B) 0.001 to 0.015 mm
(C) 0.05 to 0.02 mm
(D) 0.15 to 0.05 mm
39. In terms of maintenance, OEE stands for
- (A) Out of Every Efficiency
(B) Out of Every Effectiveness
(C) Overall Equipment Effectiveness
(D) Overall Energy Effectiveness

40. Which following document gives a graphical representation of the activity performed during manufacturing?
- (A) Work activity log
 - (B) Process chart
 - (C) Job Card
 - (D) Bill of Materials (BOM)
41. Which lubricating method is known as ring-oiling?
- (A) Gravity feed lubrication
 - (B) Force feed lubrication
 - (C) Oil pump method
 - (D) Splash lubrication
42. Which cutting fluid is preferred to steel alloys for threading?
- (A) Soluble oil
 - (B) Kerosene
 - (C) Dry air
 - (D) Lard oil
43. What is the kinetic viscosity of servo system 68 oil at 40°C?
- (A) 29.33
 - (B) 55.60
 - (C) 64.72
 - (D) 78
44. Calculate the r.p.m. for a HSS drill ϕ 19 to cut mild steel.
- (A) 498
 - (B) 503
 - (C) 118
 - (D) 608
45. Which letter drill has the largest diameter?
- (A) R
 - (B) Z
 - (C) D
 - (D) L
46. What is the diameter of 'R' letter drill?
- (A) 8.611 mm
 - (B) 10.490 mm
 - (C) 5.944 mm
 - (D) 7.036 mm

A

47. Tumbler gear mechanism in a lathe machine is used for
- (i) Change the direction of rotation of spindle
 - (ii) Change the direction of rotation of leadscrew
 - (iii) Change the direction of rotation of feed shaft
 - (iv) Change the direction of movement of carriage
- (A) Only (i) & (ii) (B) Only (i) & (iii)
 (C) Only (ii), (iii) & (iv) (D) Only (iii) & (iv)
48. Knurling is done on a workpiece to
- (i) Improve grip
 - (ii) Increase the diameter slightly
 - (iii) Enhance appearance
- (A) All of the above (i), (ii) & (iii)
 (B) Only (ii) & (iii)
 (C) Only (i) & (ii)
 (D) Only (i) & (iii)
49. What will happen if the tool is not clamped rigidly while facing?
- (A) Convex face (B) Concave face
 (C) Pip in the centre (D) None of the above
50. What is the name of the part marked 'X'?

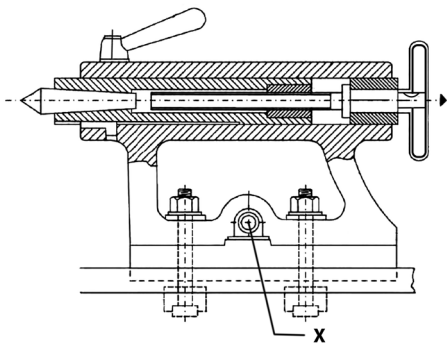

- (A) Clamping screw (B) Binder screw
 (C) Set over screw (D) Spindle locking screw

51. What is the name of the angle marked 'X'?

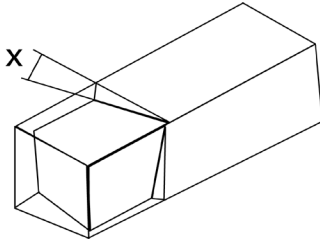

- (A) Side rake angle (B) Top rake angle
(C) Side cutting edge angle (D) Side clearance angle

52. A workpiece of diameter 60 mm undergoing turning operation. During first cut, depth of cut given is 5 mm. For second cut RPM selected is 1000. What is the cutting speed of the second cut?

- (A) 172 m/min (B) 188 m/min
(C) 35 m/min (D) 157 m/min

53. A shaft of 800 mm length is to be turned for a taper of length 250 mm. Amount of taper is 1:100. The large diameter of taper is 50 mm, what is the small diameter of taper?

- (A) 45 mm (B) 42 mm
(C) 47.5 mm (D) 46 mm

54. Find the change gears to cut a worm of 0.4 inch lead on a lathe having a lead screw of 4 TPI.

- (A) Driver teeth 70 driven teeth 50 (B) Driver teeth 50 driven teeth 127
(C) Driver teeth 80 driven teeth 50 (D) Driver teeth 80 driven teeth 100

55. What is the name of the centre shown in the fig?

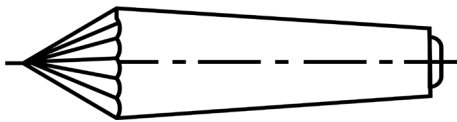

- (A) Tipped centre
(B) Frictionless centre
(C) Revolving centre
(D) Self driving live centre

A

56. Effective diameter of screw thread is measured by
- (A) Screw thread micrometer
 - (B) Vee prism
 - (C) Slip gauge and micrometer
 - (D) Vernier caliper
57. While cutting thread using single-point tool in lathe, the tool is aligned with work by using
- (A) Template
 - (B) Centre gauge
 - (C) Tail stock centre
 - (D) Surface gauge
58. How the British thread chasing dial differ from Metric thread chasing dial?
- (A) Same as metric thread chasing dial
 - (B) One worm wheel and different dial
 - (C) More than one worm wheel and different dial
 - (D) One worm wheel and one dial
59. Consider the following production operation of gear manufacturing
1. Milling with a form cutter
 2. Rack type gear shaper (gear planer)
 3. Rotary gear shaper (gear shaper)
 4. Gear hobbing
- The correct sequence of these processes in increasing order of accuracy of convolute profile of the gear is
- (A) 3, 2, 1, 4
 - (B) 2, 3, 1, 4
 - (C) 3, 2, 4, 1
 - (D) 2, 3, 4, 1

60. Milling process to mill both sides of a workpiece together, two side milling cutters are mounted at the appropriate distance apart. This configuration is known as
- (A) gang milling (B) side milling
(C) string milling (D) straddle milling
61. A milling cutter having 8 teeth is rotating at 200 rpm. If the feed per tooth is 0.1, then the table speed in mm per minute is
- (A) 80 (B) 160
(C) 187 (D) 125
62. Internal gear may be produced by
- (A) Gear milling
(B) Hobbing
(C) Gear shaping with a pinion cutter
(D) Gear shaping with a rack cutter
63. The table in a plain milling machine can be moved
- (A) Longitudinally
(B) Crosswise
(C) Vertically
(D) All of these
64. Bulky workpieces with irregular shapes are held in the milling machine table using
- (A) V block (B) Angle plate
(C) T bolt and clamps (D) Swivel vise
65. Collets are used to hold the milling cutter having _____ shank than the spindle taper.
- (A) Larger
(B) Smaller
(C) Both Smaller & Larger
(D) None

A

66. The cutter starts the cut from the machined surface and proceeds upwards and the job is fed in a direction opposite to that of cutter rotation.

Assertion (A): Internal gears are manufactured on a gear shaper.

Reason (R): Hobbing is not suitable for manufacturing internal gear

- (A) Both (A) and (R) are true and (R) is the correct explanation of (A)
- (B) Both (A) and (R) are true but (R) is not the correct explanation of (A)
- (C) (A) is true but (R) is false
- (D) (A) is false but (R) is true

67. To produce full depth spur gear by the Gear hobbing method, the number of teeth to be cut = 30, module = 3mm and pressure angle = 20°. The radial depth of cut to be employed should be equal to

- (A) 3.75mm
- (B) 4.50mm
- (C) 6.00mm
- (D) 6.75mm

68. Consider the following statements:

In Up milling process,

1. the cutter starts the cut from the machined surface and proceeds upwards
2. the cutter starts the cut from the top surface and proceeds downwards
3. the job is fed in a direction opposite to that of cutter rotation
4. the job is fed in the same direction as that of cutter rotation

Which of these statements are correct?

- (A) 1 and 3
- (B) 1 and 4
- (C) 2 and 3
- (D) 2 and 4

69. A milling cutter may have surfaces made of

- (A) High Speed Steel (HSS)
- (B) Cemented carbide
- (C) Aluminium oxide
- (D) Both (A) and (B)

70. Normally, the milling machine table is made up of

- (A) Cast iron
- (B) Steel
- (C) Wrought iron
- (D) High-carbon steel

71. Choose the correct option by analysing the statements given below related to 'types of bonds and abrasive materials used in grinding wheel'.

Statements

1. Emery, Corundum, Sandstone and Silicon carbide are natural abrasives
2. Silicon carbide is used for grinding materials like brass, copper, aluminium
3. Silicon carbide abrasive is represented by 'S'
4. Vitrified bond is not adversely affected by water, acids and oils at ordinary temperature

- (A) Statements 1, 2, 4 only are correct
(B) Statements 2, 3, 4 only are correct
(C) Statements 1, 2, 3 only are correct
(D) All the statements are correct

72. Which of the following statements is/are correct related to 'Structure of grinding wheels'?

Statements

1. Structure indicates the amount of bond present between the individual abrasive grains of grinding wheels
2. The structure of grinding wheel is specified by numbers and grinding wheels having numbers from 9 to 15 indicates dense structure
3. A close structured wheel will not produce good surface finish when compared to open structured wheel
4. A close structured wheel is used to finish the grinding of hard and brittle materials

- (A) Statements 1, 2 and 3 are correct
(B) Statement 1 is only correct
(C) Statements 1, 2 and 4 are correct
(D) Statements 1 and 4 are correct

A

73. COLUMN-A contains 'different types of bonds used in grinding wheels'. COLUMN-B contains 'uses and indications of those bonds in COLUMN-A'. Choose the right option in which COLUMN-A & COLUMN-B are matched correctly.

COLUMN-A	COLUMN-B
1. Oxychloride bond	a. Denoted by 'R'
2. Resinoid bond	b. Denoted by 'E'
3. Rubber bond	c. Bond is for making segmented type grinding wheels
4. Shellac bond	d. Denoted by 'B'

(A) 1-b, 2-a, 3-d, 4-c

(B) 1-c, 2-a, 3-d, 4-b

(C) 1-c, 2-d, 3-a, 4-b

(D) 1-a, 2-c, 3-d, 4-b

74. The specification of a grinding wheel is given as "51 A 36 L 5 V 23". Analyse the statements given below and choose the correct option

Statements

1. 'A' indicates the types of bonds

2. '36' indicates the structure of wheel

3. 'L' indicates the types of abrasive used in grinding wheel

4. 'V' indicates the grade of grinding wheel

(A) Only statement 1 is correct

(B) Only statement 3 is correct

(C) All the statements are correct

(D) All the statements are wrong

75. Which of the following abrasive material is most suitable for grinding cast iron material?

(A) Aluminium oxide

(B) Diamond

(C) Silicon carbide

(D) White aluminium oxide

76. Which of the following statements related to 'dressing and truing of grinding wheels' is/are correct?

Statements

1. When a new grinding wheel is mounted on the machine, it must be trued before use
2. Sometimes a grinding wheel is also trued to change the shape of the grinding wheel face
3. While grinding soft metals like aluminium, copper etc, the condition occurs when metal particles get clogged between abrasive particles of grinding wheel is called Glazing
4. Abrasive stick type dresser is used when only light dressing of grinding wheel is required

(A) Only statement 1 is correct

(B) Statements 1, 3 and 4 are correct

(C) Statements 1, 2 and 4 are correct

(D) All the statements are correct

77. Which shape of grinding wheel is used for gashing milling cutter teeth?

(A) Saucer type

(B) Straight cup

(C) Segmented type wheels

(D) None of the above

78. Which tool is accommodated with radius grinding attachment of tool and cutter grinder for forming radius on the grinding wheel?

(A) High-carbon steel tool

(B) Brazed tip tool

(C) High-speed steel tool

(D) Diamond stick

79. Find the cutting speed of grinding wheel in meter/second, if the spindle of the wheel is operated at 1000 RPM and the diameter of grinding wheel is 600mm.

(A) 15.7

(B) 31.4

(C) 15700

(D) 31400

A

80. Choose the correct option by analysing the statements given below related to grinding.

Statements

1. Flaring cup-shaped grinding wheel is used for sharpening milling cutters and reamers
2. When compared to dry grinding, wet grinding process will produce good surface finish
3. In a cylindrical grinder, the work material should be mounted in between centres only before starting (switching on) the hydraulic system
4. In a grinding machine, if the grinding wheel runs faster than the recommended speed, then there arises a chance of clogging of wheel

- (A) Statements 2 and 3 are only correct
(B) Statements 1, 2 and 4 are only correct
(C) Statement 2, 3 and 4 are only correct
(D) All the above four statements are true

81. The NC/CNC control system in which several axes can be simultaneously controlled is known as

- (A) Point-to-point control system (B) Straight line control system
(C) Contouring control system (D) None of the above

82. In the 3-Dimensional Cartesian Coordinate system of CNC machine tools, Positive Z movement (+Z) is in the direction that

- (A) Increases the distance between the work piece and the tool
(B) Decreases the distance between the work piece and the tool
(C) Does not affect the distance between the work piece and the tool
(D) Either increases or decreases the distance between the work piece and the tool depending on other axes movements

83. In accordance to the PLC program developed for a specific machine, the M Code used for Spindle on clock-wise rotation is

- (A) M02 (B) M03
(C) M04 (D) M05

84. A microcomputer that stores the program and executes the commands into actions by the machine tool is known as

- (A) Driving System (B) Feedback System
(C) Input Device (D) Machine Control Unit

85. ATC in CNC means
(A) Automatic Tool Changer (B) Accurate Tool Changer
(C) Animated Tool Changer (D) Accelerated Tool Changer
86. Drill chuck adaptor is a
(A) Cutting tool (B) Work holding device
(C) Tool holding device (D) None of the above
87. The G word in each block of a Part Program represents
(A) Sequence number (B) Preparatory word
(C) Spindle speed (D) Tool selection
88. The CNC Code used to stock removal in turning for CNC Lathe is
(A) G 71 (B) G 72
(C) G 73 (D) G 74
89. In a CNC machine, a manual mode that allows the operator to move the axes and spindles of the machine is
(A) Auto Mode (B) MDI Mode
(C) MPG Mode (D) JOG Mode
90. In CNC Lathe, the relationship between Feed rate per minute & Feed rate per revolution is
(A) Feed per minute = Spindle Speed \times Feed per revolution
(B) Feed per revolution = Spindle Speed \times Feed per minute
(C) Feed per revolution = Spindle Speed + Feed per minute
(D) Feed per minute = Spindle Speed + Feed per revolution
91. The component of a CNC vertical machining centre that controls the servo motor movements by sending low energy commands is
(A) MCU (B) Interpreter
(C) ATC (D) Pulse transmitter
92. In the continuous path method of motion control system, which of the following interpolation methods is not used?
(A) Linear (B) Cylindrical
(C) Helical (D) Parabolic

98. Cutting tool wear caused due to ion exchange phenomenon between tool and workpiece causing oxidation and subsequent breakdown is
- (A) attrition wear
 - (B) diffusion wear
 - (C) electrochemical wear
 - (D) abrasion wear
99. When plotted on a log-log graph, the relationship between tool life and cutting speed can be represented using a
- (A) straight line
 - (B) parabola
 - (C) hyperbola
 - (D) C-curve
100. With respect to a CNC in operation, what do you understand by the term "Jog"?
- (A) A dial control to fine-tune feed rate
 - (B) A switch that stops the normal range of axis travel
 - (C) A normal movement of the CNC axis instituted by the operator
 - (D) A red button that halts all axis motions
-

A

SPACE FOR ROUGH WORK