

085/2022

Maximum : 100 marks

Time : 1 hour and 30 minutes

1. The strain energy due to bending stress is :

(A) $\int \frac{M^2 dx}{EI}$

(B) $\int \frac{M^2 dx}{4EI}$

(C) $\int \frac{M^2 dx}{2EI}$

(D) $\int \frac{M dx}{2EI}$

2. A cantilever is subjected to a uniformly distributed load w kN/m. It is propped by a spring of stiffness k to the same level as that of the fixed end, before loading. The reaction at the prop will be :

(A) $\frac{3}{8} wl + k$

(B) $\frac{3}{8} wl - k$

(C) $wl \left[\frac{(3/8)}{1 - \frac{3EI}{kl^3}} \right]$

(D) $wl \left[\frac{(3/8)}{1 + \frac{3EI}{kl^3}} \right]$

3. In a beam of length L , four possible influence line diagrams for shear force at a section located at a distance of $L/4$ from the left and support (marked as P , Q , R and S) are shown below. The correct influence line diagram is :

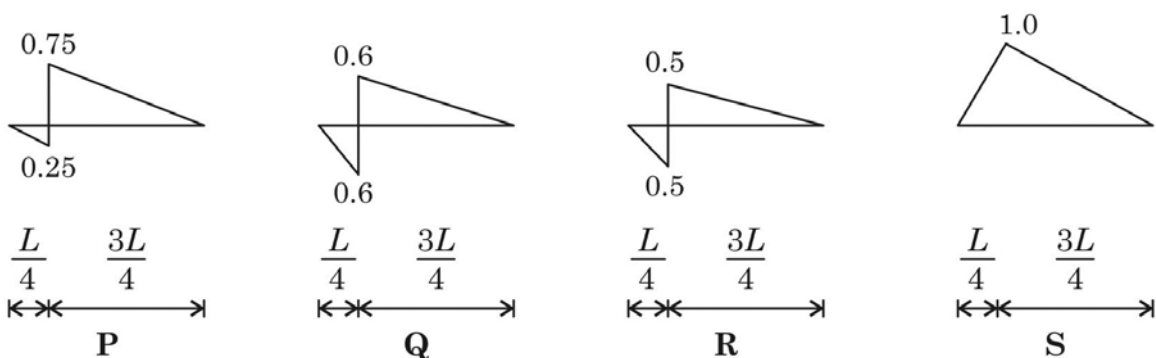

- (A) P
(C) R

- (B) Q
(D) S

4. A three hinged parabolic arch having a span of 20 m and a rise of 5 m carries a point load of 10 kN at quarter span from the left end as shown in the figure. The resultant reaction at the left support is :

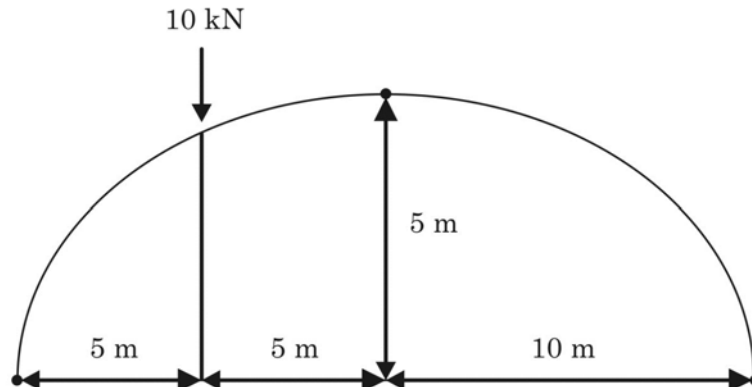

- (A) 9.01 kN
 (B) 5 kN
 (C) 7.50 kN
 (D) 2.50 kN
5. A simply supported beam is subjected to a uniformly distributed load of intensity w per unit length, on half of the span from one end. The length of the span and the flexural stiffness are denoted as l and EI , respectively. The deflection at mid-span of the beam is :

- (A) $\frac{5}{6144} \frac{wl^4}{EI}$
 (B) $\frac{5}{768} \frac{wl^4}{EI}$
 (C) $\frac{5}{384} \frac{wl^4}{EI}$
 (D) $\frac{5}{192} \frac{wl^4}{EI}$

6. Find the force in the member AB :

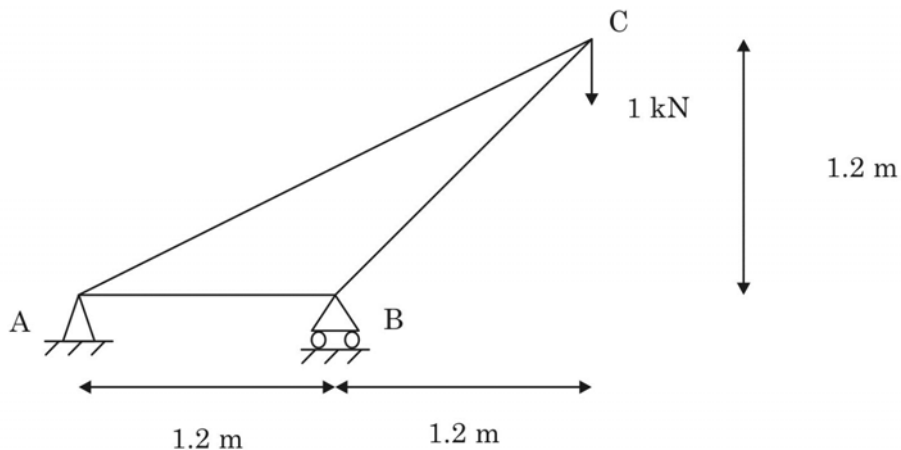

- (A) 2 kN Compression
 (B) 2 kN Tension
 (C) 1 kN Compression
 (D) Zero kN

7. The ratio of the theoretical critical buckling load for a column with fixed ends to that of another column with the same dimensions and material, but with pinned ends, is equal to :
- (A) 0.5 (B) 1
(C) 2 (D) 4
8. A fixed beam AB of length L carries a concentrated load at midspan. The moment of inertia of the beam from either end to a distance of $L/4$ is I and it is $2I$ for the remaining length. Fixed end moment at A will be :
- (A) $\frac{3WL}{4}$ (B) $\frac{WL}{48}$
(C) $\frac{5WL}{4}$ (D) $\frac{5WL}{48}$
9. A circle of diameter 200 mm is inscribed inside a mild steel plate before it is stressed, as shown in the Figure. After the application of the tensile stresses f_x , f_y and the shear stress q , the circle deforms into an ellipse. The length of the major axis of the ellipse is :

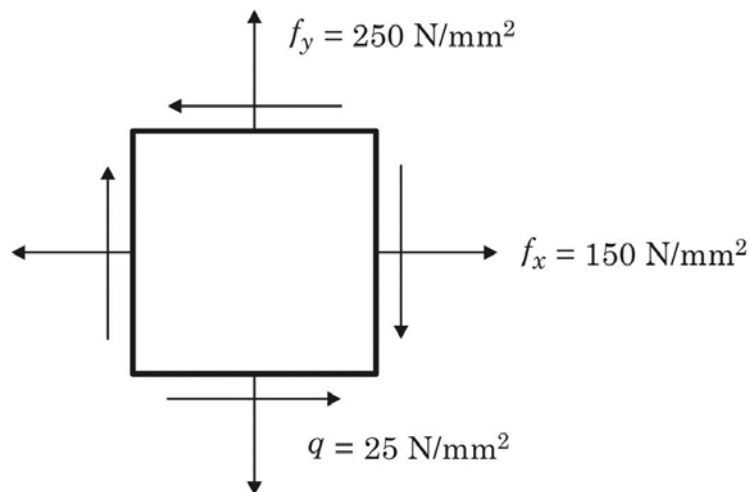

Assume $E = 200$ GPa and Poisson's ratio = 0.25.

- (A) 200.8 mm (B) 200.5 mm
(C) 200.22 mm (D) 200.08 mm

10. Two vertical bars one of steel and other of bronze each 2 m long and of equal area of cross section hang vertically with 700 mm distance between their axes. A rigid member is connected to the lower ends of the bars. Calculate at what distance from the steel bar should a concentrated load of 70 kN be applied on the rigid member so that elongation of the bronze bar will be 1.5 times that of steel bar. Take modulus of elasticity of steel and bronze as 200 GPa and 100 GPa respectively :

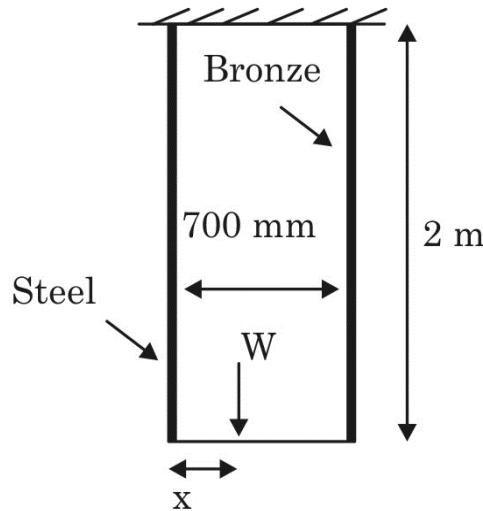

- (A) 500 mm (B) 400 mm
(C) 350 mm (D) 300 mm
11. The ordinates of a 2 hr unit hydrograph at 1 hr intervals starting from time $t = 0$ are 0, 3, 8, 6, 3, 2 and 0. A storm of 6.6 cm occurs uniformly over the catchment in 3 hrs. If the ϕ -index is 2 mm/hr and base flow is 5 cumecs, the peak flow of the storm is :
- (A) 24 m³/s (B) 36 m³/s
(C) 41 m³/s (D) 49 m³/s
12. Which one is the possible case of an S² profile?
- (A) Flow behind a weir in steep sloped channel
(B) Flow behind a sluice gate in a mild sloped channel
(C) Flow over a free overfall in steep sloped channel
(D) Flow just at the downstream of a steep sloped channel
13. A discharge of 30 l/sec was measured by using a right angled triangular notch. While measuring the head over the notch, an error of 1.5 mm was made. If the coefficient of discharge for the notch is 0.62, the % error in the discharge measurement will be approximately :
- (A) 0.75 (B) 1.05
(C) 1.5 (D) 1.75

14. Two pipelines, one carrying oil of relative density 0.9 and other carrying water are connected to a manometer as shown in Figure. By what amount, the pressure in water pipeline should be increased so that mercury levels in both the limbs of the manometer become equal?

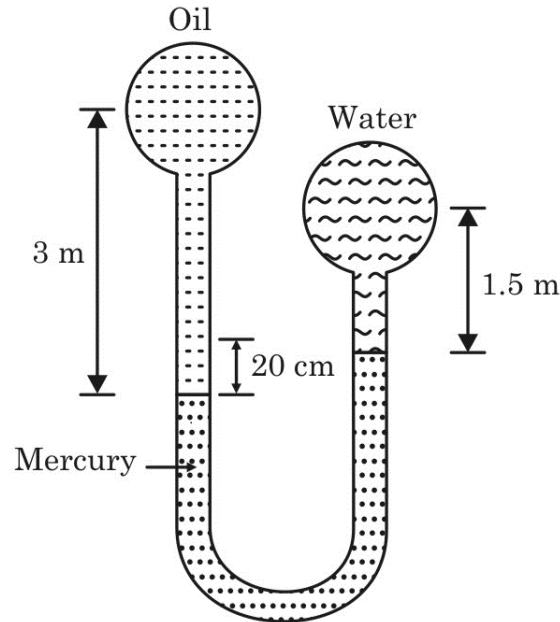

- (A) 7.41 kPa
(B) 14.92 kPa
(C) 12.41 kPa
(D) 24.82 kPa
15. The flow of glycerin (kinematic viscosity = 5×10^{-4}) in an open channel is to be modeled in a laboratory flume, using water (kinematic viscosity = 10^{-6}) as flowing fluid. If both gravity and viscosity are important, what should be the ratio of prototype to model dimension for maintaining dynamic similarity?
- (A) 1
(B) 23
(C) 63
(D) 200
16. A water course commands an irrigated area of 1000 ha. The intensity of irrigation of rice is 70%. The transplantation of crop takes 15 days and during transplantation period total depth of water required by the crop on the field is 500 mm. During the transplantation period, the useful rain falling on the field is 120 mm. Assuming the loss of water in the watercourse as 20%, the discharge at the head of the water course will be :
- (A) $2.05 \text{ m}^3/\text{s}$
(B) $2.6 \text{ m}^3/\text{s}$
(C) $5.73 \text{ m}^3/\text{s}$
(D) $10.26 \text{ m}^3/\text{s}$

17. A spillway discharges flood at a rate of $9 \text{ m}^3/\text{s}$ per metre width. If the depth of flow on the horizontal apron at the toe of the spillway is 50 cm, the minimum length of apron required at the downstream should be at least :
- (A) 2 m (B) 9 m
(C) 15 m (D) 25 m
18. A cube 50 cm side is inserted in a two-layer fluid with specific gravities 1.2 and 0.9. The upper and lower halves of the cube are composed of materials with specific gravity 0.6 and 1.4 respectively, determine the depth of the top of the cube above the interface :
- (A) 3.33 cm (B) 13.33 cm
(C) 25.1 cm (D) 33.33 cm
19. Most economical circular section for maximum velocity condition is :
- (A) hydraulic radius is 81% of the diameter
(B) flow depth is 81% of the diameter
(C) hydraulic radius is 95% of the diameter
(D) flow depth is 95% of the diameter
20. A large irrigation canal can be approximated as a wide rectangular channel and Manning's formula is applicable to describe the flow in it. If the gauge is related to discharge Q as :
- $$Q = C(G - \alpha)^{\beta}$$
- (A) 1.67 (B) 1.33
(C) 0.67 (D) 0.33
21. The average compressive strength of common burned clay brick of class 35 is :
- (A) 35 N/mm^2 (B) 35 N/cm^2
(C) 35 kN/mm^2 (D) 35 t/cm^2
22. Brick frog is :
- (A) Projection on the brick face (B) Depression on the brick face
(C) Impression of a frog on the brick (D) Brick made of a frog and clay
23. Where is rebar used?
- (A) Mat Foundation (B) Framed structure
(C) RCC Beam (D) All of the above

24. Aggregate in which most of which passes through 4.75 mm IS sieve is called as :
(A) Rubble (B) Coarse aggregate
(C) Fine aggregate (D) 4.75 mm aggregate
25. What is the pH value of water used for reinforced cement concreting?
(A) Shall not be less than 6 (B) Shall not be greater than 6
(C) Equal to 6 (D) Shall not be equal to 6
26. The compaction of concrete in the drilled pile hole is done by compressed air in the case of :
(A) Simplex pile (B) Franki pile
(C) Pressure pile (D) Vibro pile
27. Pile which resist horizontal thrust is called as :
(A) Raymond pile (B) Franklin pile
(C) Batter pile (D) Franki pile
28. The additional lines which are measured to show the correctness of the chain surveying are called :
(A) Tie lines (B) Proof lines
(C) Check lines (D) All of the above
29. The Limit of plane survey is :
(A) 260 sq. mile (B) 260 sq. km
(C) 260 sq.m (D) 260 sq. foot
30. Measuring with a 30 m chain, 0.01 m too short, introduces :
(A) Positive cumulative error (B) Negative cumulative error
(C) Positive compensating error (D) Negative compensating error
31. In India Geodetic survey was conducted by :
(A) CPWD (B) PWD
(C) Consultancy firms (D) Survey of India department
32. Total station is used for :
(A) Levelling
(B) Measurement of inclined distances
(C) Measurement of horizontal and vertical angles
(D) All of the above

33. What is the temperature for preheating of bricks for the water absorption test in degree Celsius?
- (A) 100 (B) 110
(C) 120 (D) 130
34. How much depth of water is required initially for efflorescence test of bricks in cm?
- (A) 2.5 (B) 4.5
(C) 5 (D) 7.5
35. What is the minimum compressive strength of first class bricks in kg/sq.cm?
- (A) 25 (B) 35
(C) 75 (D) 140
36. An example of metamorphic rock :
- (A) Granite (B) Limestone
(C) Slate (D) Dolomite
37. An example of foliated rock :
- (A) Gniess (B) Granite
(C) Basalt (D) Sand stone
38. A good stone should not absorb water more than _____% water by its weight.
- (A) 1 (B) 3
(C) 5 (D) 7
39. As per IS 269 the weight of magnesia in cement shall not exceed by _____%.
- (A) 2 (B) 3
(C) 4 (D) 5
40. Determining the cost of the construction project, after calculating the quantities of items is called :
- (A) Accounting (B) Costing
(C) Quantity surveying (D) Estimating
41. The rate of a civil engineering construction work depends on :
- (A) Equipment cost (B) Material cost
(C) Labour cost (D) All the above

42. Which of the following item of work is not included in the plinth area estimate?
(A) Cantilever porch (B) Work area
(C) Toilet (D) Room
43. The service unit of a stable building is :
(A) Number of beds (B) Number of people
(C) Number of animals (D) Area of the building
44. Brickwork is not measured in cubic meters for the following work :
(A) two brick wall (B) one brick wall
(C) half brick wall (D) none of the above
45. A dummy activity :
(A) Consumes time (B) Consume resources
(C) Real activity (D) None of the above
46. Sinking fund is :
(A) Fund to prevent sinking of building in water during flood
(B) Fund for maintenance costs
(C) Fund for rebuilding a structure after its economic life
(D) Fund for extra works
47. During tender submission, the contractor should deposit _____ as a guarantee of the tender.
(A) Security deposit (B) Earnest money
(C) Caution deposit (D) None of the above
48. CPM is the :
(A) Project oriented technique (B) Activity oriented technique
(C) Event oriented technique (D) Finish oriented technique
49. PERT is the :
(A) Project Oriented Technique (B) Activity Oriented Technique
(C) Event Oriented Technique (D) Finish Oriented Technique
50. The time an activity completion can be delayed without affecting the early start of the next activities is called :
(A) Total float (B) Free float
(C) Interfering float (D) Successive float

51. The method ideal for forecasting future population of a stabilized old city or small town is :
- (A) Decreasing rate method (B) Arithmetical increase method
(C) Geometrical increase method (D) Incremental increase method
52. Which among the following is absent in hard water?
- (A) Calcium carbonate (B) Calcium chloride
(C) Calcium sulphate (D) Calcium nitrate
53. The water treatment process, sedimentation aided with coagulation is mainly aimed at removing
- (A) Settleable solids (B) Dissolved solids
(C) Colloidal solids (D) Floating solids
54. The disinfectant that has advantages of causing no bad taste, no odour and no danger of overdose is
- (A) Ozone (B) Ultra-violet rays
(C) Chlorine (D) Potassium permanganate
55. Which of the following principles is true for the design of distribution system?
- (A) Available terminal pressure-head and the permissible pressure-head must be same
(B) Available terminal pressure-head must be more than the permissible pressure-head
(C) Available terminal pressure-head must be less than the permissible pressure-head
(D) Available terminal pressure-head must be equal to total head loss
56. The 5 day 20°C BOD represents
- (A) The nitrogenous demand
(B) The total nitrogenous and carbonaceous demand
(C) The carbonaceous demand
(D) The ultimate oxygen demand
57. The process taking place in trickling filter is
- (A) Aerobic suspended growth process (B) Anaerobic suspended growth process
(C) Anaerobic attached growth process (D) Aerobic attached growth process

58. Which of the following represents a plain sedimentation unit with longer detention period?
(A) Primary sedimentation unit (B) Detritus tank
(C) Septic tank (D) Humus tank
59. The process of washing of sludge to remove excess salt during sludge treatment is
(A) Elutriation (B) Conditioning
(C) Sloughening (D) Desalination
60. For successful results, the UASB reactor must operate under
(A) Thermophillic conditions (B) Mesophilic conditions
(C) Psychrophillic conditions (D) Ambient temperature conditions
61. The limiting value of the depth of neutral axis ($x_{u,max}/d$) for Fe 415 grade steel bars as per IS 456-2000 is
(A) 0.53 (B) 0.48
(C) 0.51 (D) 0.46
62. The maximum shear stress of M30 concrete permitted in N/mm^2 (limit state method) as per IS 456-2000 is
(A) 2 (B) 2.5
(C) 3 (D) 3.5
63. Basic Value of span to effective depth ratio for span up to 10 m of a simple supported beam as per IS 456-2000
(A) 7 (B) 20
(C) 24 (D) 26
64. The maximum area of steel in mm^2 has to be provided in a column of size 200 mm \times 700 mm is
(A) 8400 (B) 2800
(C) 4200 (D) 11200
65. For Nominal mix concrete, what is the quantity water (liters) used for a bag of cement as per IS 456-2000, if the Grade of concrete is M10
(A) 45 (B) 34
(C) 28 (D) 25

66. What is the minimum stripping period to remove the prop of a beam of span 5.8 m as per IS 456-2000 is
- (A) 12 days (B) 14 days
(C) 7 days (D) none of above
67. What is the minimum tension reinforcement in mm^2 for a beam having effective depth 415 mm and width 300 mm. Use M20 concrete and Fe 415 steel
- (A) 300 (B) 415
(C) 255 (D) 150
68. The modulus of Elasticity of M25 Concrete may be taken as _____ N/mm^2 .
- (A) 25000 (B) 20000
(C) 28500 (D) 30000
69. Torsional reinforcement is required at the corners of rectangular slab whose edges are :
- (A) continuous (B) discontinuous
(C) free (D) curved
70. Normally structures exceeding _____m in length are designed with one or more expansion joints as per IS 456-2000.
- (A) 25 (B) 35
(C) 45 (D) 60
71. The value of development length should be taken as _____ times the bar diameter if M20 concrete and Fe 415 steel is used.
- (A) 57 (B) 37
(C) 47 (D) none of above
72. The maximum spacing of shear reinforcement measured along the axis of the member shall not exceed _____ for vertical stirrups (d is the effective depth of the member)
- (A) 0.75 d (B) 0.5 d
(C) 0.25 d (D) 1.0 d
73. When a concrete is subjected to uniform compression as in the case of a concentrically loaded short column, the ultimate strain is limited to 0.002 and corresponding design stress is
- (A) $0.87 f_{ck}$ (B) $0.447 f_{ck}$
(C) f_{ck} (D) $0.67 f_{ck}$

74. Mention the code of practice for design of structural timber in building
(A) IS 883 – 1970 (B) IS 885 – 1970
(C) IS 800 – 1984 (D) IS 875 – 1980
75. Plain concrete gravity retaining wall are not used for heights exceeding for _____ obvious economic reasons.
(A) 10 m (B) 1 m
(C) 3 m (D) 20 m
76. The density of steel may be taken as
(A) 78 kN/m³ (B) 785 kN/m³
(C) 7.85 kN/m³ (D) None of above
77. In the absence of test data, the approximate value of shrinkage strain for design in prestressed concrete shall be taken as _____ for pre-tensioning systems as per IS 1343 – 1980.
(A) 0.0005 (B) 0.005
(C) 0.0003 (D) 0.003
78. The permissible concrete stress in shear of M20 in calculation relating to resistance to cracking as per IS 3370 – 1965 part II is
(A) 20 kg/cm² (B) 12 kg/cm²
(C) 14 kg/cm² (D) 17 kg/cm²
79. The permissible concrete stress in tension due to bending of M40 in calculation relating to resistance to cracking as per IS 3370 – 1965 part II is :
(A) 20 kg/cm² (B) 24 kg/cm²
(C) 34 kg/cm² (D) 40 kg/cm²
80. The method of prestressing concrete in which the tendons are tensioned before concreting is
(A) pre tensioning (B) post tensioning
(C) initial prestressing (D) jack tensioning

81. Dry density of a soil sample is defined as the ratio of :
- (A) Total mass of soil sample to total volume of soil sample
 - (B) Total mass of soil sample to volume of soil solids
 - (C) Mass of soil solids to total volume of soil sample
 - (D) Mass of soil solids to volume of soil solids
82. Which of the following can be the unit of coefficient of permeability?
- (A) cm/sec
 - (B) N/cm²
 - (C) cm²/sec
 - (D) cm/sec²
83. Which of the following is an incorrect statement as per Mohr's strength theory?
- (A) Critical failure shear depends upon soil properties and normal stress
 - (B) Ultimate shear strength of soil is determined by the stresses on the potential failure plane
 - (C) When soil material is subjected to three dimensional principal stresses the failure criterion is dependent on intermediate principal stress
 - (D) The plot of shear stress and normal stress corresponding to failure is called strength envelope
84. If a clay soil deposit is never been subjected to an effective pressure greater than existing overburden pressure and is completely consolidated under existing pressure is called as :
- (A) Under consolidated
 - (B) Pre-consolidated
 - (C) Over consolidated
 - (D) Normally consolidated
85. Which of the following is a correct statement?
- (A) As dry density increases due to compaction permeability increases
 - (B) For same density, fine grained soil compacted dry of optimum are more permeable than those compacted wet of optimum
 - (C) Shear strength of compacted soil is not dependent on dry density and moulding water content
 - (D) For same density, soil sample compacted wet of optimum shrink less than sample compacted dry of optimum

86. Failure of slopes takes place due to :
- (A) Action of gravitational force (B) Seepage forces
(C) Excavation (D) All of the above
87. Failure is accompanied by tilting of footing in the case of :
- (A) Local shear failure (B) General shear failure
(C) Punching shear failure (D) All types of shear failures
88. _____ type of foundation is used to eliminate differential settlement in soil containing compressible lenses.
- (A) Strap footing (B) Spread footing
(C) Cantilever footing (D) Raft footing
89. A curve connecting all points of equal vertical pressure below the ground surface is called :
- (A) Newmark's chart (B) Stress path
(C) Isobar (D) Mohr's circle
90. Which of the following statements is true?
- (A) Earth pressure at rest is greater than active earth pressure
(B) Earth pressure at rest is less than active earth pressure
(C) Earth pressure at rest is equal to active earth pressure
(D) None of the above
91. _____ is the instrument used in manual method of spot speed study.
- (A) Clinometer (B) Enoscope
(C) Radar (D) Co-axial tube
92. Ideal transition curve for horizontal curve on highways is
- (A) Parabola (B) Cubic parabola
(C) Leminiscate (D) Spiral
93. Average loss in weight of aggregates to be used for pavement construction after 10 cycles of immersion in $MgSO_4$ and drying shall not exceed :
- (A) 6% (B) 12%
(C) 18% (D) 24%

94. Level of service representing capacity level of two lane rural highways without access control is :
- (A) LOS C (B) LOS D
(C) LOS E (D) LOS F
95. Grade compensation to be provided on a B.G. railway track at a horizontal curve is :
- (A) 0.04% per degree of curve (B) 0.03% per degree of curve
(C) 0.02% per degree of curve (D) 0.01% per degree of curve
96. Which of the following is not a navigational aid?
- (A) Light house (B) Beacon
(C) Breakwater (D) Buoy
97. _____ method is used for tunneling in soft ground having water bearing strata.
- (A) Drift method (B) Full face method
(C) Compressed air method (D) Heading and bench method
98. The imaginary line designating a border around a town segregating a non-development zone is called as :
- (A) Cordon line (B) Green belt
(C) Screen line (D) None of the above
99. The strip of pavement joining runway to apron is called :
- (A) Taxiway (B) Terminal
(C) Hangar (D) Shoulder
100. The largest zone in a town is :
- (A) Industrial zone (B) Commercial zone
(C) Recreational zone (D) Residential zone

SPACE FOR ROUGH WORK

SPACE FOR ROUGH WORK